

Polar PWT, the best way to prevent FW piping replacement:

Freshwater stabiliser

+

Corrosion protection, red water removal and pipe cleaning.

- Stops red coloured water.
- Removes rust and scale from piping system, original flow re-stored.
- Protects all piping construction from further corrosion.
- Avoids stain problems in laundry.

Polar PWT package consists of:

- Polar rust and scale dissolving unit (item 11) with sacrificial anodes and magnetic strainer. This unit will continuously dissolve existing deposits of rust and scale. It is installed after the hydrophore pump, this to treat all the water in the system.
- Polar rust and scale dissolving unit (item 18) with sacrificial anodes and magnetic strainer. This unit is installed after the hot water circulation pump for continuously treatment of the re-circulating hot water.
- Dosing pump (item 7) for red water removal.
- 100 ltrs. dosing tank (item 8).
- Polar PWT freshwater stabiliser. Polar PWT is widely used in waterworks throughout the world. For marine, it is delivered in 25ltrs. drums.
- 1 pc. complete installation kit.

FW system need shut down for approx. 3 to 4 hours to allow Polar PWT complete package installation of rust and scale removal units.

The immediate process of obtaining clean water in the system normally takes 1-2 weeks.

FRESHWATER HYDROPHORE SYSTEM

INDEX:

1. Water from Freshwater Tanks.
2. Hydrophore pumps.
3. Hydrophore tank.
4. Hotwater Heater.
5. Hotwater Circulation pump.

6. POLAR COLD WATER TREATMENT.
7. Dosing pump.
8. Dosing tank.
9. Water meter.
10. Injection point with non-return Valve.
11. Polar Rust and Scale dissolving Unit.
12. Polar Magnetic Strainer.
13. Shut-off Valve.
14. By-Pass Valve.
15. Signal Cable.
16. Electric Connector.

17. POLAR HOT WATER TREATMENT.
18. Polar Rust and Scale dissolving Unit.
19. Polar Magnetic Strainer.
20. Shut-off Valve.

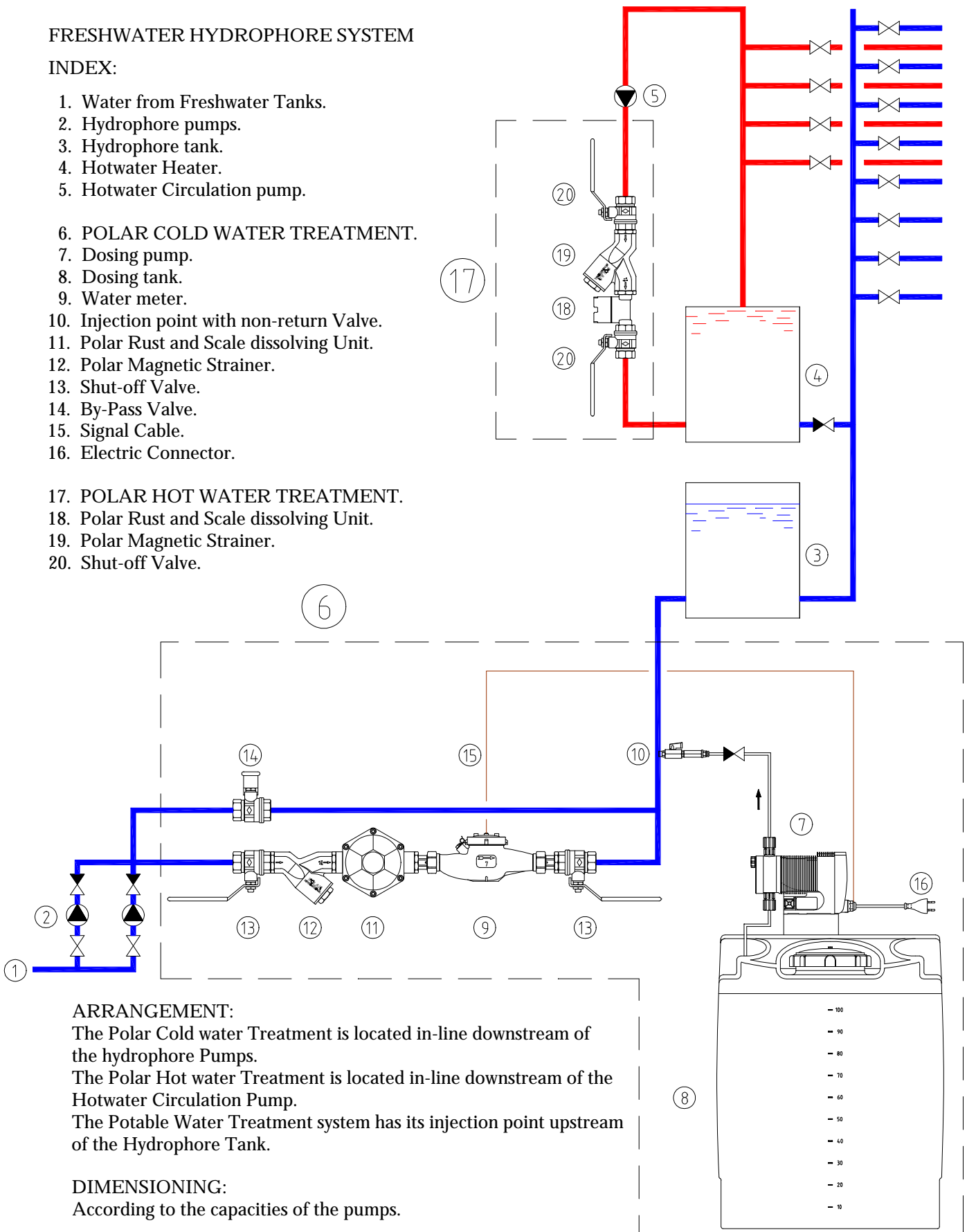

ARRANGEMENT:

The Polar Cold water Treatment is located in-line downstream of the hydrophore Pumps.
 The Polar Hot water Treatment is located in-line downstream of the Hotwater Circulation Pump.
 The Potable Water Treatment system has its injection point upstream of the Hydrophore Tank.

DIMENSIONING:

According to the capacities of the pumps.

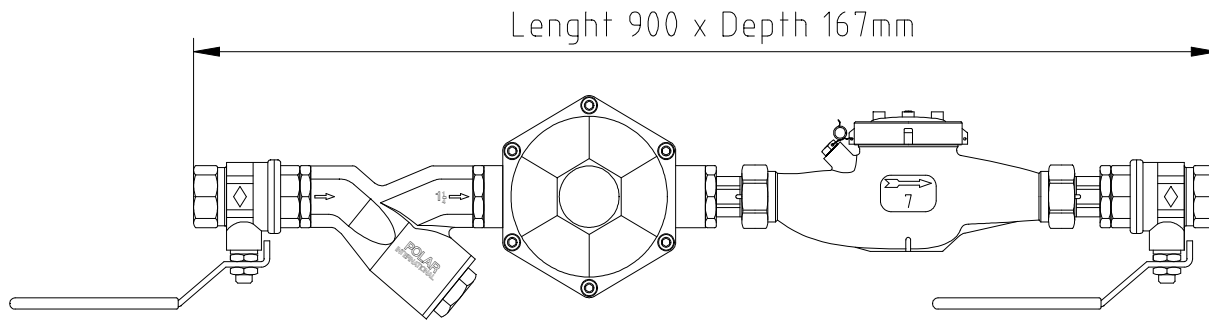

Polar Cold Water Treatment

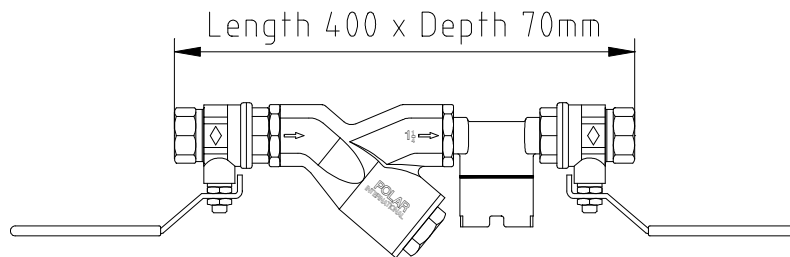

Polar Hot Water Treatment

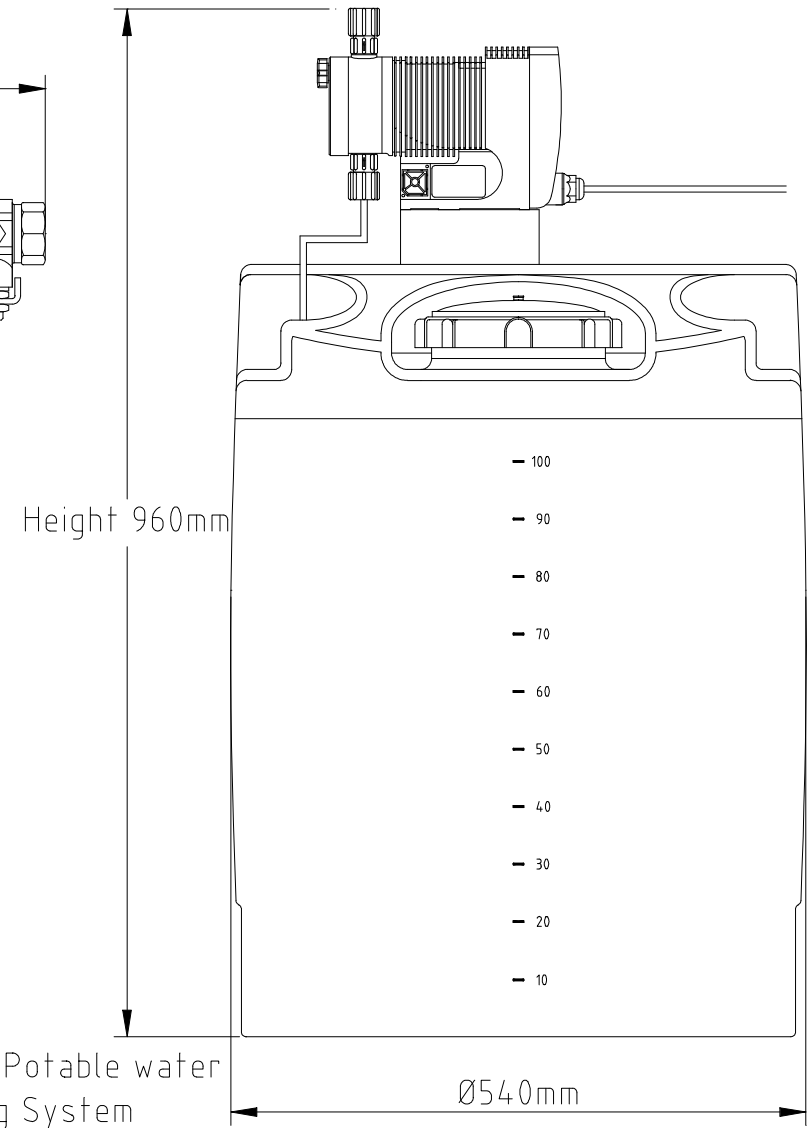

Polar Potable water
Dosing System